

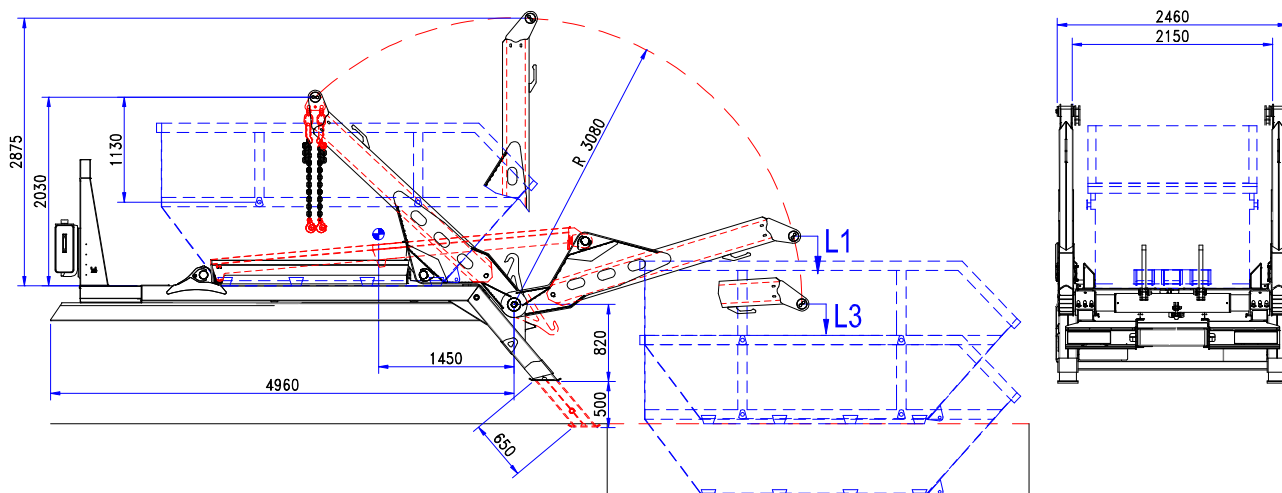

b.o.b. Sistemi Idraulici S.p.A.

AZIENDA CON SISTEMA
DI GESTIONE QUALITÀ
CERTIFICATO DA DNV
= ISO 9001 =

« MB 16 fixed arms »



Technical features

- Fixed twin arms
- L1: Lifting capacity at ground level ton 16
- L3: Lifting cap. 800 mm under the ground level ton 11
- No. 3 flow controls with ground hand levers
- Rear independent stabilizing feet
- Tipping hooks with ground control
- Front oil tank with support frame
- Adjustable platform wedges
- Painting in bottom antirust red or grey chassis colour Operating manual and spare parts book
- Basic equipment weight: kg 3.050 ca.*)

**) The weight is indicative and referred to the basic skip loader without options, accessories and ancillary equipments (platform extension, front cab protection, cylinders protection carter, rear headstock protection carter, etc.)*

Options

- Integrated subframe H 180 mm
- No. 4 adjustable chains with safety hook locks
- Front cab protection panel
- Front platform extension
- Mechanical security on tipping hook (DIN 30720)
- Landing feet rollers
- Hoisting cylinders rods protection carter
- Regenerating oil system (double speed)
- Arms connecting bar
- Electro-pneumatic cab control on mobile hand-board
- Monitoring led arms in resting position
- Monitoring led for stabilizing feet
- Visual or sonorous signalling of tipping hooks position
- Rear lights integrated in the headstock carter

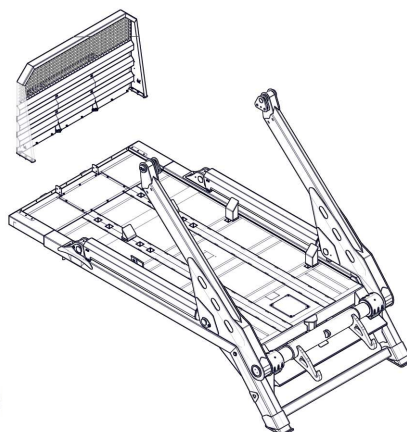
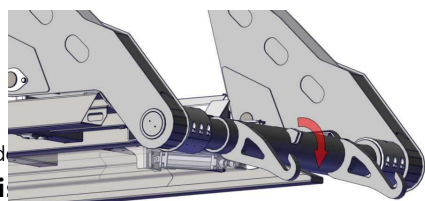
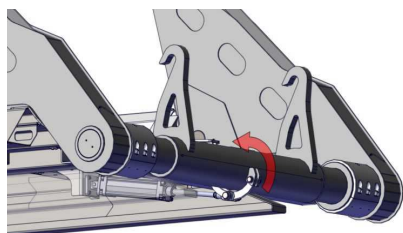

The technical d

B.O.B. Si

P. I.V.A. 00496180043 - Tel.: +39 (0173) 780002/3 - Fax: +39 (0173) 780004

Internet: www.bobspa.com - E-mail: info@bobitalev.com

ut prior notice.

N) - Italia