

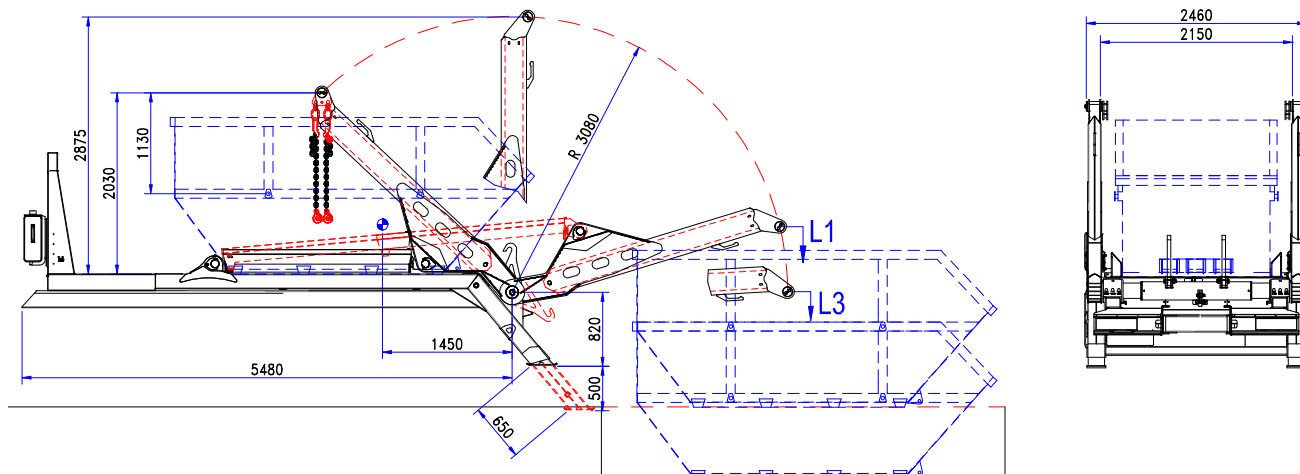

b.o.b. Sistemi Idraulici S.p.A.

AZIENDA CON SISTEMA
DI GESTIONE QUALITÀ
CERTIFICATO DA DNV
= ISO 9001 =

« MB 18 fixed arms »



Technical features

- Fixed twin arms
- L1: Lifting capacity at ground level ton 18
- L3: Lifting cap. 800 mm under the ground level ton 12,5
- No. 3 flow controls with ground hand levers
- Rear independent stabilizing feet
- Tipping hooks with ground control
- Front oil tank with support frame
- Adjustable platform wedges
- Painting in bottom antirust red or grey chassis colour Operating manual and spare parts book
- Basic equipment weight: kg 3.250 ca.*)

*) The weight is indicative and referred to the basic skip loader without options, accessories and ancillary equipments (platform extension, front cab protection, cylinders protection carter, rear headstock protection carter, etc.)

Options

- Integrated subframe H 180 mm
- No. 4 adjustable chains with safety hook locks
- Front cab protection panel
- Front platform extension
- Mechanical security on tipping hook (DIN 30720)
- Landing feet rollers
- Hoisting cylinders rods protection carter
- Regenerating oil system (double speed)
- Arms connecting bar
- Electro-pneumatic cab control on mobile hand-board
- Monitoring led arms in resting position
- Monitoring led for stabilizing feet
- Visual or sonorous signalling of tipping hooks position
- Rear lights integrated in the headstock carter



The technical details shown in this sheet are indicative and can be changed by the builder without prior notice.

B.O.B. Sistemi Idraulici S.p.A. – Regione Oltre Rea, 32 – 12060 Monchiero (CN) - Italia

P. I.V.A. 00496180043 - Tel.: +39 (0173) 780002/3 – Fax: +39 (0173) 780004

Internet: www.bobspa.com - E-mail: info@bobitalev.com