



SCM 010-130 ISO is a range of robust axial piston motors especially suitable for mobile hydraulics.

SCM 010-130 ISO is of the bent-axis type with spherical pistons. The design results in a compact motor with few moving parts, high starting torque and high reliability. It covers the entire displacement range 10-130 cm³/rev. at a maximum pressure of 400 bar. It's well dimensioned, double tapered roller bearings permit high shaft loads and lead to excellent speed characteristics. The motor's high level of reliability is based on the choice of materials, hardening methods, surface structures and the quality assured manufacturing process.

Other advantages:

- High maximum speed
- Smooth operation over the entire speed range
- Available in many different configurations of shafts and connections
- High efficiency
- Speed sensor available as option
- Suitable for applications with high angular accelerations due to its high rotary stiffness

Motor SCM 010-130 ISO		010	012	017	025	034	040	047	056	064	084	090	108	130
Displacement	cm ³ /rev	9.6	12.6	17.0	25.4	34.2	41.2	47.1	56.7	63.5	83.6	90.7	108.0	130.0
Working pressure														
<i>max intermittent</i>	bar	400	400	400	400	400	400	400	400	400	400	400	400	350
<i>max continuous</i>		350	350	350	350	350	350	350	350	350	350	350	350	300
Revolutions														
<i>max intermittent</i>	rpm	8800	8800	8800	7000	7000	6300	6300	6300	6300	5200	5200	5200	5200
<i>max continuous</i>		8000	8000	8000	6300	6300	5700	5700	5700	5700	4700	4700	4700	4700
<i>min continuous</i>		300	300	300	300	300	300	300	300	300	300	300	300	300
Power														
<i>max intermittent</i>	kW	41	54	74	86	115	125	145	175	195	215	230	275	285
<i>max continuous</i>		15	20	25	40	55	60	65	80	90	100	110	130	135
Starting torque theoretical value	Nm/bar	0.15	0.20	0.27	0.40	0.54	0.66	0.75	0.89	1.0	1.33	1.44	1.71	2.06
Moment of inertia (x 10 ⁻³)	kg m ²	0.9	0.9	0.9	1.1	1.1	2.6	2.6	2.6	2.6	7.4	7.4	7.4	7.4
Weight	kg	8.5	8.5	8.5	9.5	9.5	16.5	16.5	16.5	16.5	28.0	28.0	30.5	30.5

Data concerning RPM are based on maximum permitted peripheral velocity of the tapered roller bearing.
 Max intermittent power data may vary dependent on application. For further information please contact Sunfab.
 Continuous power data are based on maximum output power without external cooling of the motor housing.
 Intermittent duty is defined as follows: max 6 seconds per minute, e.g. peak RPM when unloading or accelerating.

Versions, main data

Example

SC	M	010	W	N	I41	W25	K3	G	1	00
Line	1	2	3	4	5	6	7	8	9	10

Line	SC	Sunfab Compact, bent-axis design
------	----	----------------------------------

1. Type	M	Motor
---------	---	-------

2. Displacement	010 012 017 025 034 040 047 056 064 084 090 108 130
-----------------	---

3. Direction of rotation	W	Independent
--------------------------	---	-------------

4. Sealing	N	Nitrile
	H	High pressure, nitrile
	V	Viton

5. Mounting flange	ISO 3019-2	010 012 017 025 034 040 047 056 064 084 090 108 130
I41	ISO 4-h ø80	X X X - - - - - - - - - -
I42	ISO 4-h ø100	- O O X X - - - - - - - - - -
I43	ISO 4-h ø125	- - - - - X X X X - - - - - -
I44	ISO 4-h ø140	- - - - - - - - - X X O O
I45	ISO 4-h ø160	- - - - - - - - - O O X X

6. Shaft	010 012 017 025 034 040 047 056 064 084 090 108 130	
Spline DIN 5480		
W20	W20x1.25x14x9g	X X X - - - - - - - - - -
W25	W25x1.25x18x9g	X X X X O - - - - - - - - - -
W30	W30x2x14x9g	- - - X X X X X O - - - - - -
W32	W32x2x14x9g	- - - - - X X X O - - - - - -
W35	W35x2x16x9g	- - - - - X X X X X X - - - -
W40	W40x2x18x9g	- - - - - - - - - X X X X X
W45	W45x2x21x9g	- - - - - - - - - O O X X
Key DIN 6885		
K20	ø 20 k6	X X X - - - - - - - - - -
K25	ø 25 k6	X X X X O - - - - - - - - - -
K30	ø 30 k6	- O O X X X X X O - - - - - -
K35	ø 35 k6	- - - - - X X X X - - - - - -
K40	ø 40 k6	- - - - - - - - - X X O O
K45	ø 45 k6	- - - - - - - - - O O X X

X = Standard, preferred
O = Contact Sunfab

7. Connection cover		010 012 017 025 034 040 047 056 064 084 090 108 130
S1	40° Mount flange vertical *	- - - - - - - - - X X X X
S2	40° Mount flange horizontal *	- - - - - X X X X - - - -
S3	40° threaded connection	X X X X X - - - - - - - -
V1	90° Mount flange vertical *	- - - - - - - - - X X X X
V2	90° Mount flange horizontal *	- - - X X X X X X X X X X
R1	Side connections, flanged *	- - - X X X X X X X X X X
K3	Combclover 90° side conn. thread .	X X X X X - - - - - - - -

* According to SAE J518 code 62

8. Connections		010 012 017 025 034 040 047 056 064 084 090 108 130
G	ISO G*	X X X X X - - - - - - - -
M	Metric **	- - - X X X X X X X X X X
U	UN***	- X X X X X X X X X X X X

* Only threaded connections
** Only flanged connections
*** Only available for S covers

9. Additional	1	External drainage
---------------	---	-------------------

10. Speed sensor		010 012 017 025 034 040 047 056 064 084 090 108 130
00	No speed sensor	X X X X X X X X X X X X X
P1	Prepared for speed sensor	X X X X X X X X X X X X X
S1	Fitted speed sensor type PNP*	X X X X X X X X X X X X X
S2	Fitted speed sensor type NPN*	X X X X X X X X X X X X X

* See separate brochure "Speed sensor hall" for more information.



Dimensions SCM 010-017

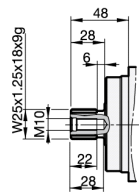
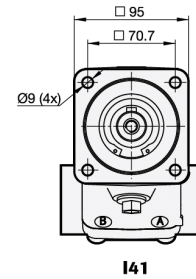
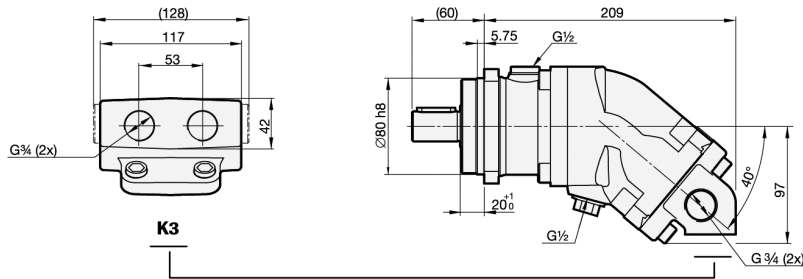
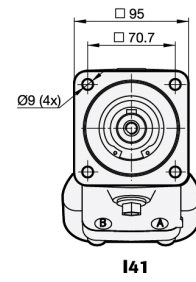
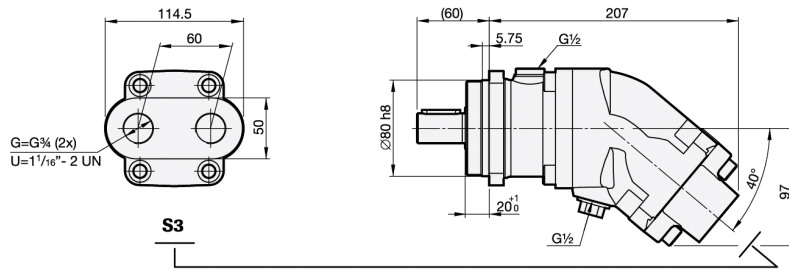

W25

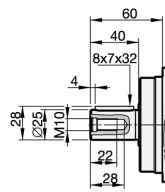

K25

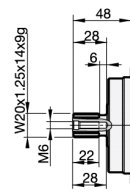

W20

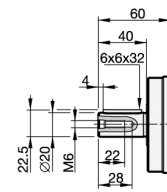

K20

SCM 025-034

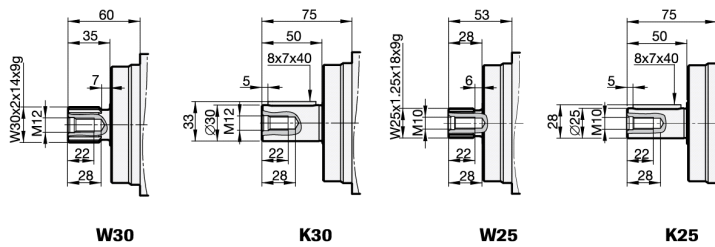
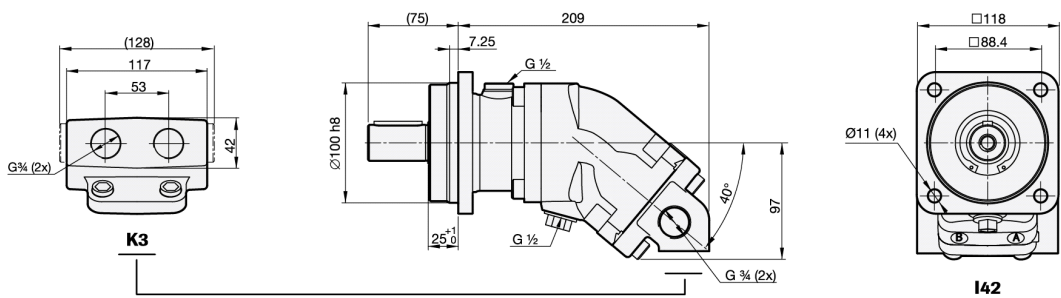
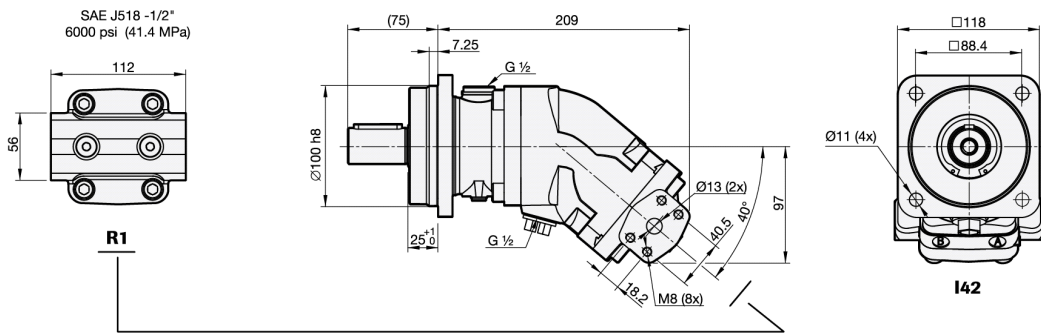
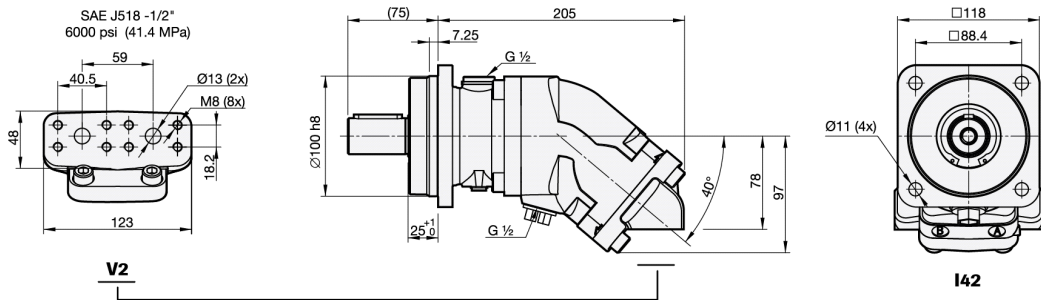
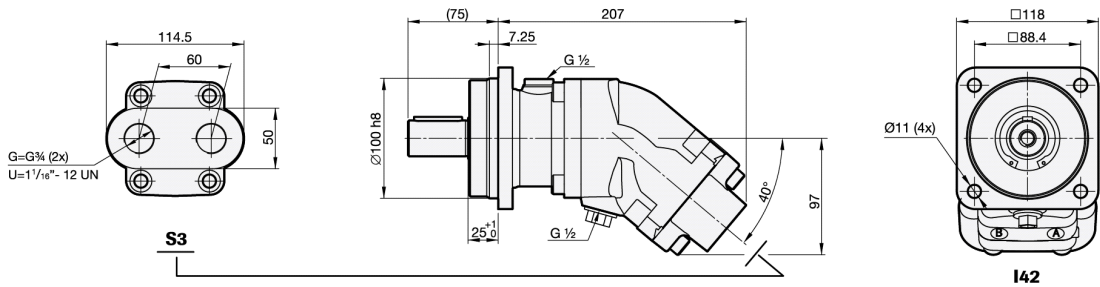

SCM 040-064

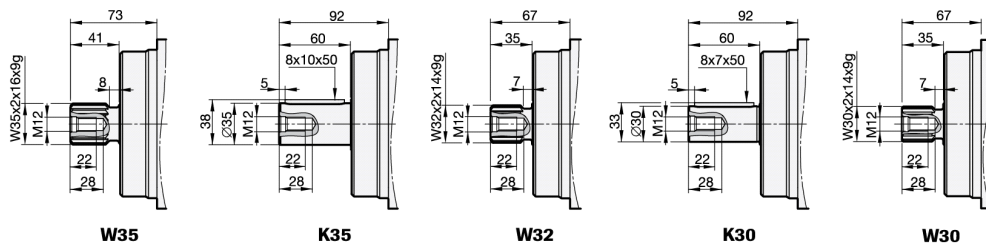
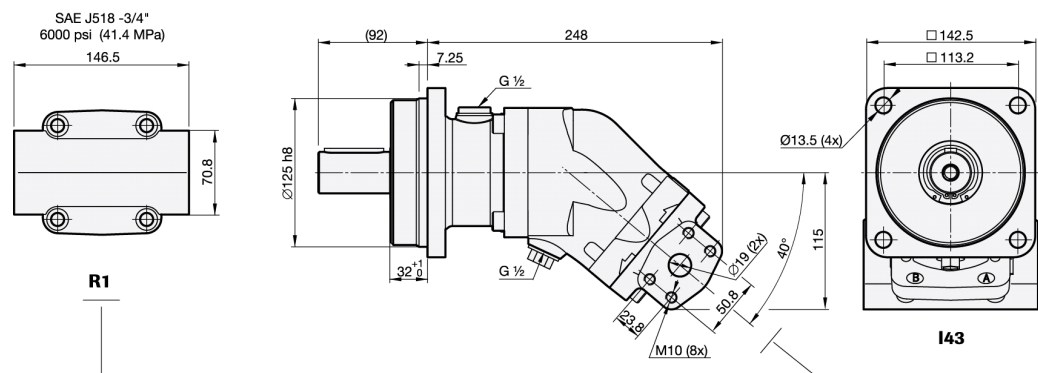
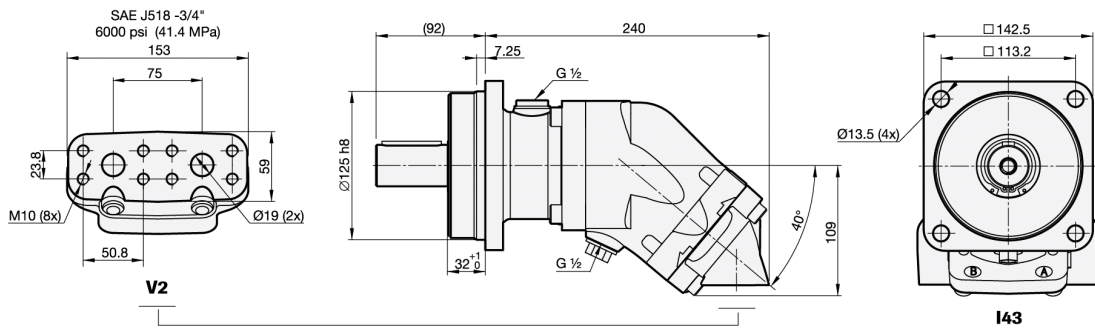
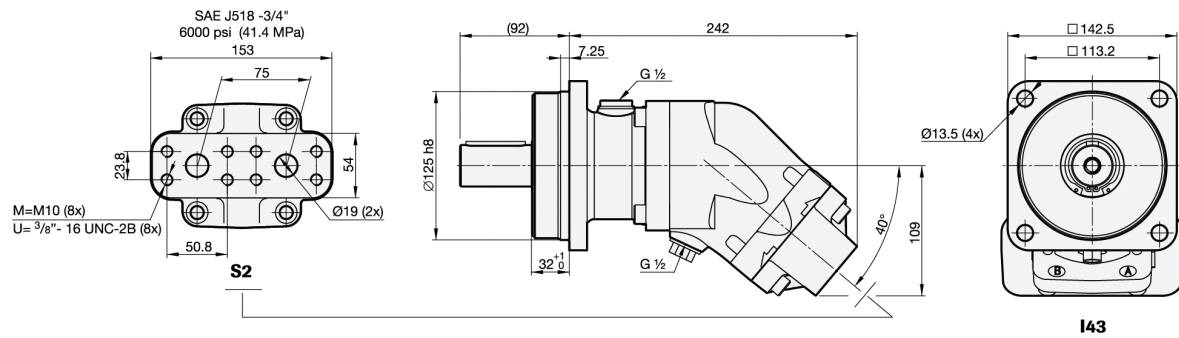

SCM 084-090

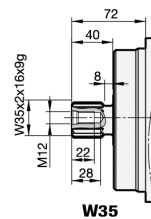
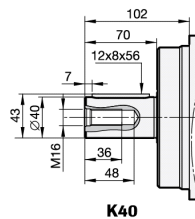
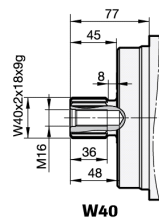
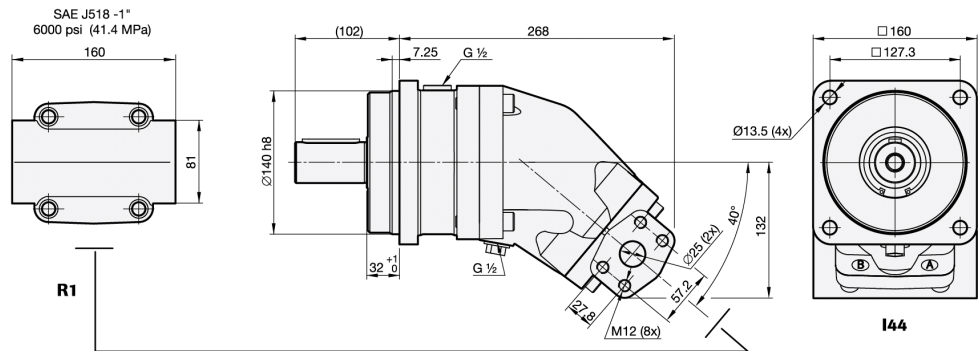
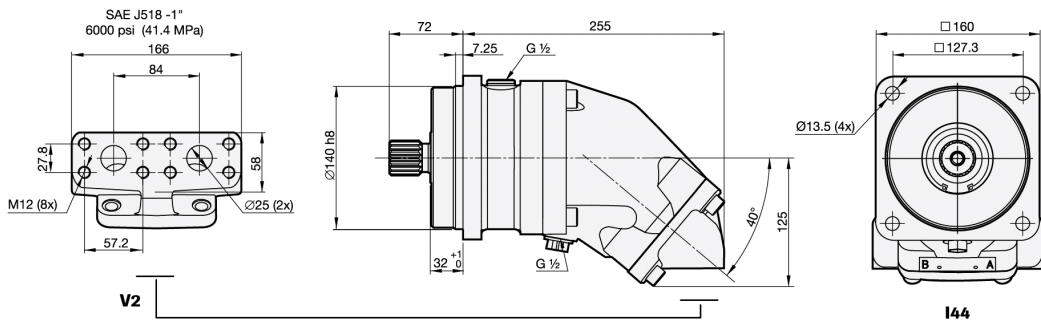
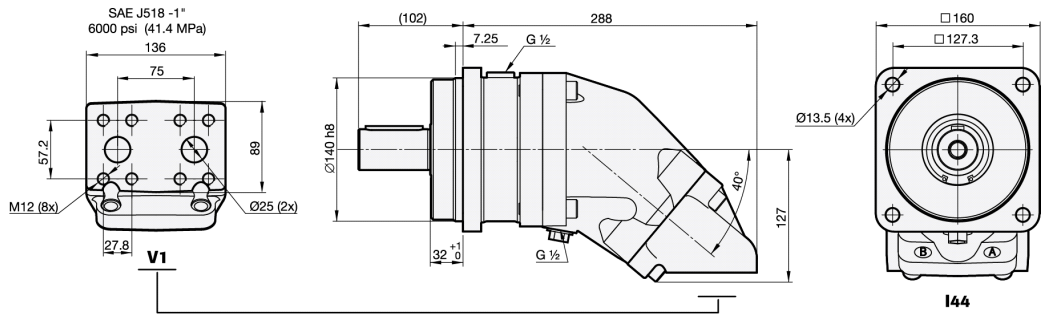
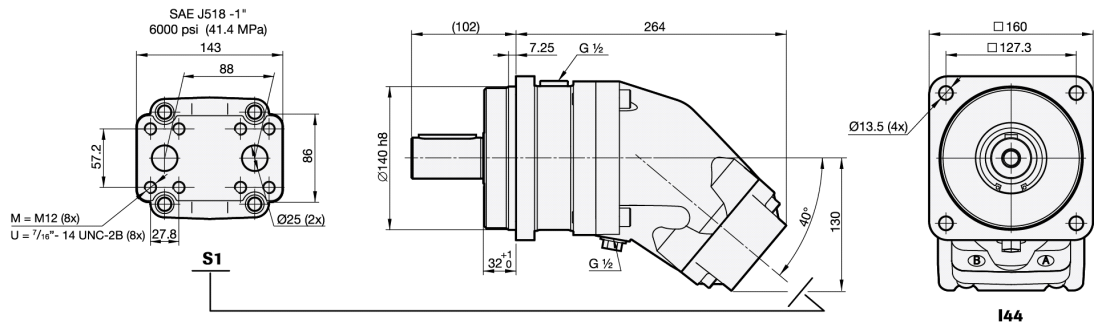

SCM 108

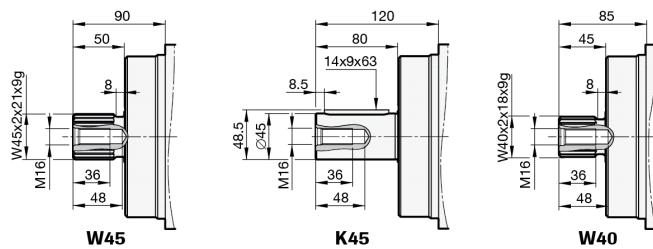
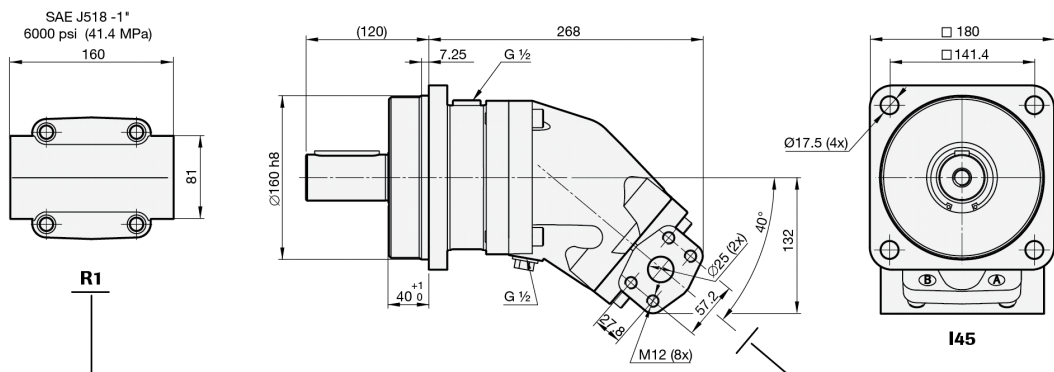
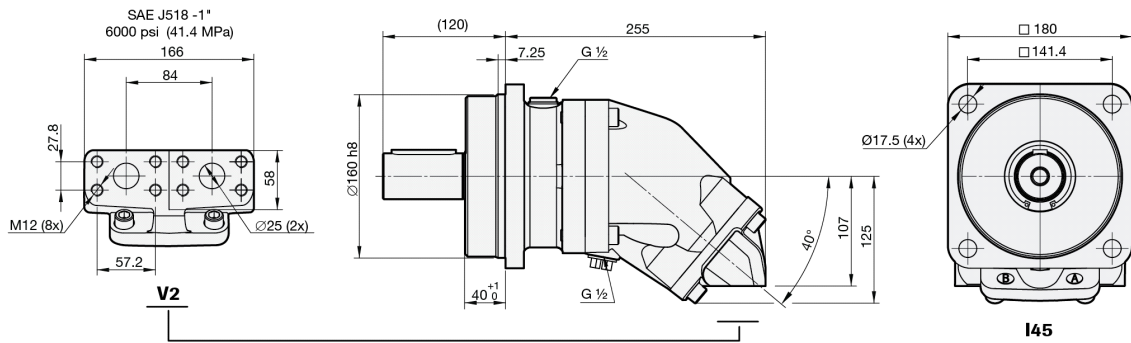
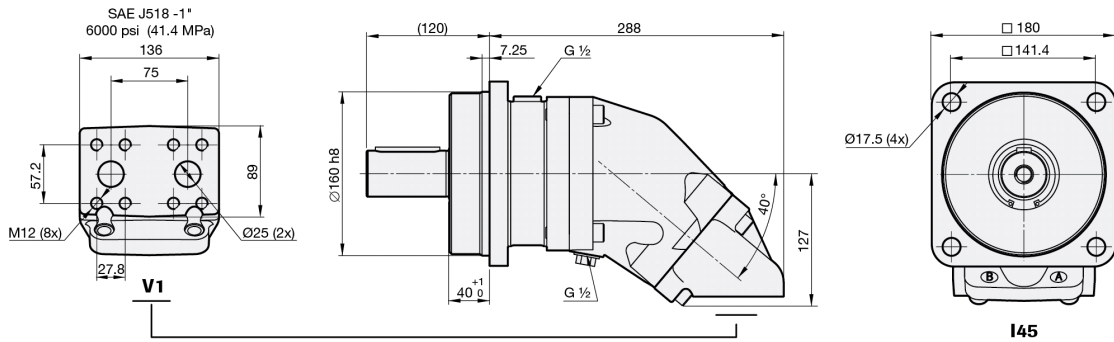
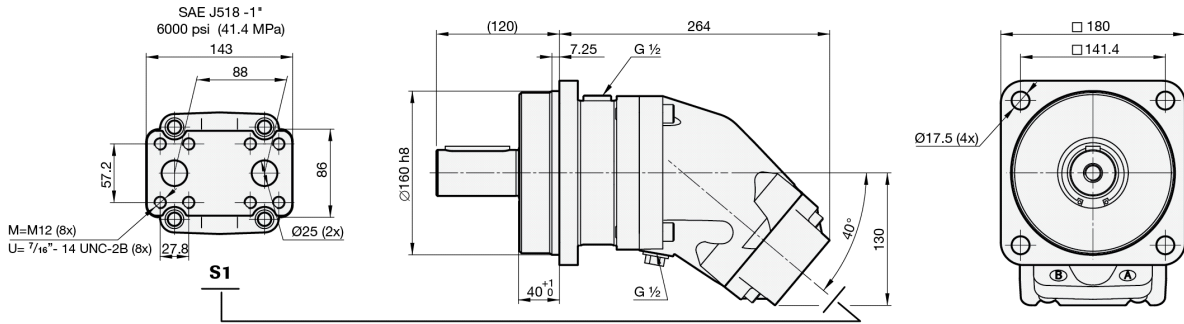

SCM 130

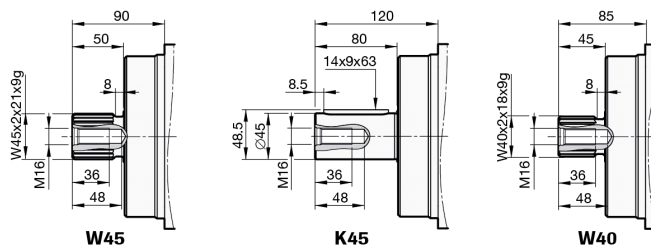
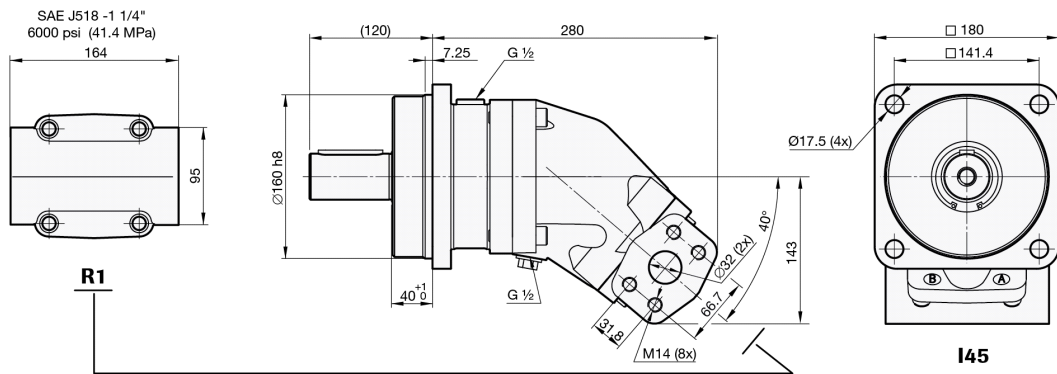
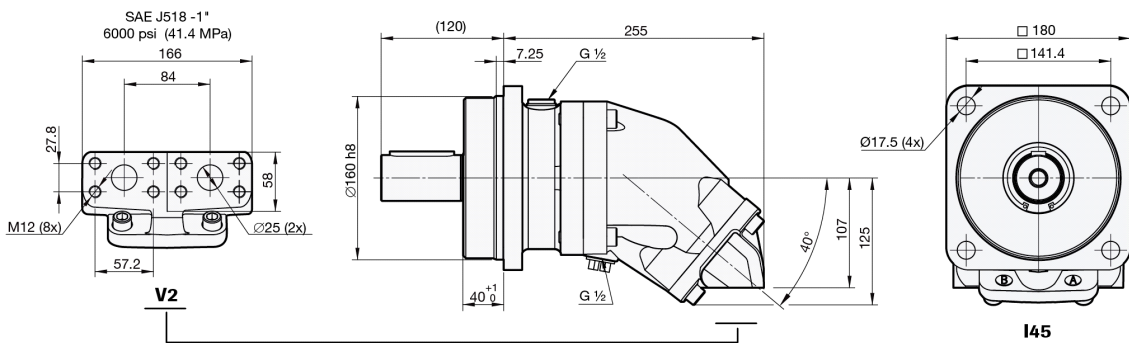
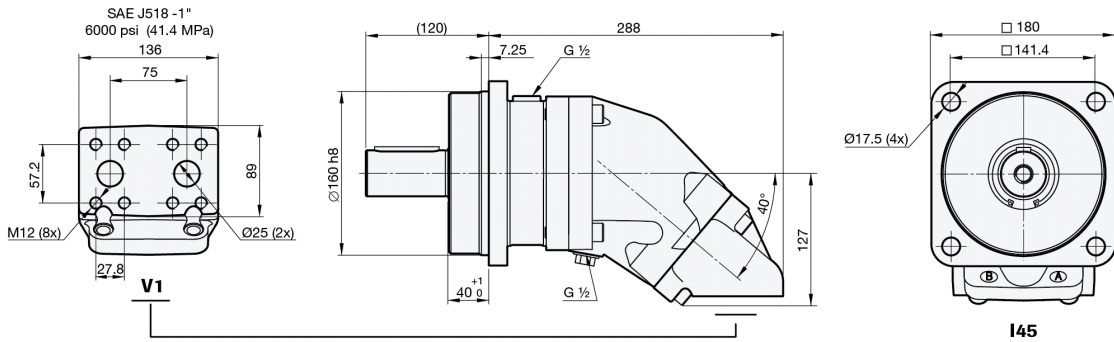
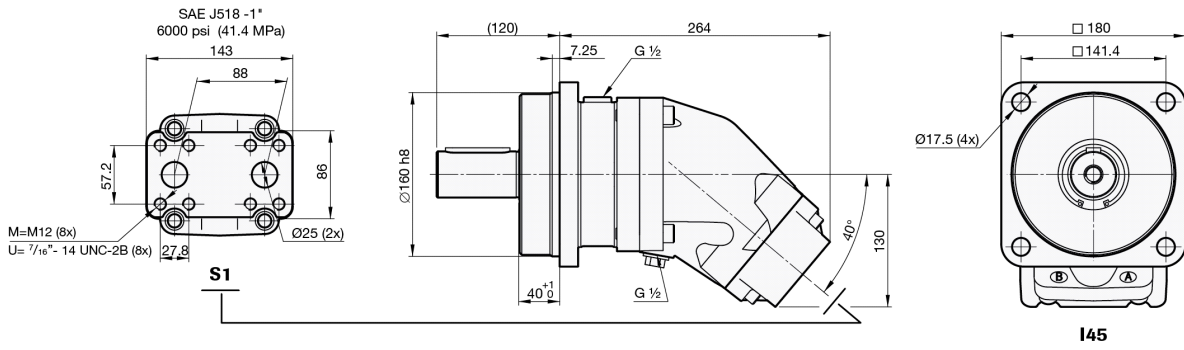

General instructions

Choice of shaft seal

Motor SCM	Code	Temp. °C	Max. housing pressure bar at rpm								
			1000	2000	3000	4000	5000	6000	7000	8000	9000
010-034	N	75	5.5	2.7	1.8	1.4	1.1	0.9	0.8	0.7	0.6
	H	75	24.6	12.3	8.2	6.1	4.9	4.1	3.5	3.1	2.7
	V	90	5.5	2.7	1.8	1.4	1.1	0.9	0.8	0.7	0.6
040-064	N	75	5.5	2.7	1.8	1.4	1.1	0.9	0.8		
	H	75	24.6	12.3	8.2	6.1	4.9	4.1	3.5		
	V	90	5.5	2.7	1.8	1.4	1.1	0.9	0.8		
084-130	N	75	3.8	1.9	1.3	1.0	0.8	0.6			
	H	75	17.2	8.6	5.7	4.3	3.4	2.9			
	V	90	3.8	1.9	1.3	1.0	0.8	0.6			

Code according to page 2, Versions, main data

Factors affecting the choice of shaft seal include the hydraulic motor housing pressure and the drainage oil temperature.

The drainage oil should have a maximum temperature of 75 °C with a Nitrile shaft seal and 90 °C with a Viton shaft seal. These temperatures must not be exceeded.

The housing pressure must be equal to or greater than the external pressure on the shaft seal.

Shaft loads

The life of the motor is highly dependent on the bearing life. The bearings are affected by operating conditions such as speed, pressure, oil viscosity and filtration.

External load on the shaft, as well as its size, direction and location also affects the bearing life.

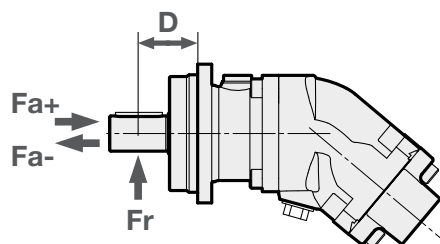

Optimal force direction of radial load

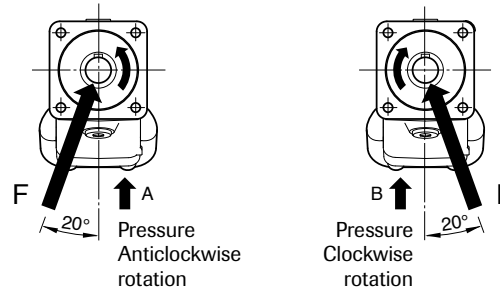

SCM ISO Max recommended shaft loads		010	012	017	025	034	040	047	056	064	084	090	108	130
Fr (radial) max ¹	kN	7	7	7	8	8	8.5	8.5	9	9	12	12.5	12.5	13
Distance D (to point of force)	mm	45	45	45	50	50	60	60	60	60	65	65	70	70
Fa (axial) + (at standstill/ 0 bar pressure) max	kN	3	3	3	3	3	4	4	4	4	5	5	5	5
Fa (axial) - (at standstill/ 0 bar pressure) max	kN	4	4	5	7	7	7	7	10	11	13	14	16	19
Fa (axial) + (at 400 bar pressure) max ²	kN	4	4	5	7	7	7	7	10	11	13	14	16	19
Fa (axial) - (at 400 bar pressure) max ²	kN	0	0	0	0	0	0	0	0	0	0	0	0	0

¹) Fr (radial) max; Calculation based on running conditions: 300 bar / 2000 rpm

¹) Fr (radial) max; Calculation based on optimal force direction (Fr max will be lower in other force directions)

¹) Fr (radial) max; In running conditions higher than 300 bar and/or 2000 rpm the max limits for Fr (radial) max will be lower

²) Fa (axial) + Will increase bearing life

²) Fa (axial) - Will decrease bearing life

For other forces, please contact Sunfab for advice.

Temperatures/Housing cooling

Excessive system temperature reduces the life of the shaft seal and can lower the oil viscosity below the recommended level. A system temperature of 60 °C and a drain flow temperature of 90 °C must not be exceeded.

Cooling/flushing of the motor housing can be needed to keep the drain flow temperature at an acceptable level.

Suggested flow:

Motor SCM	Flushing l/min	Cont. RPM
010-034	2-8	≥ 2800
040-064	4-10	≥ 2500
084-130	6-12	≥ 2200

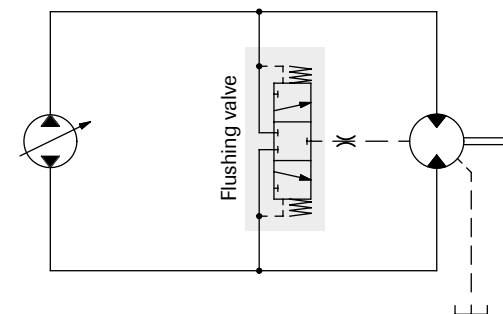
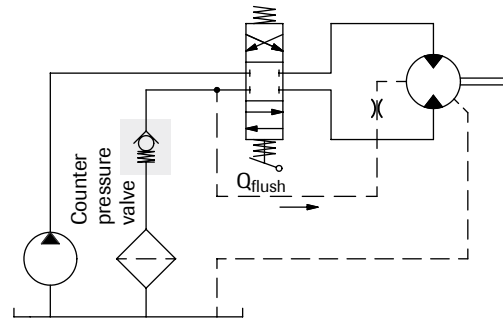
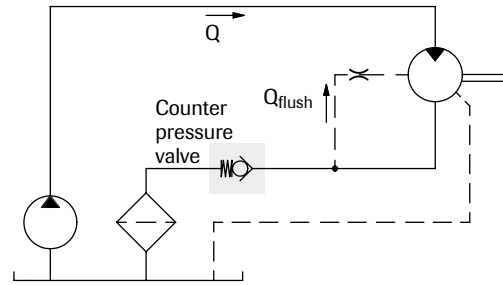
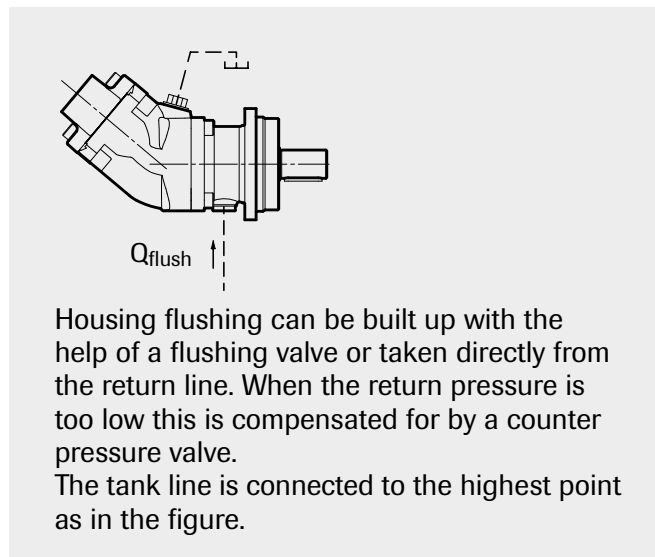

Simplified circuits

Installation

- The motor housing should be filled with oil to at least 50% before starting.
- The drainage pipe should be connected to topmost drainage outlet.
- The other end of the pipe should be connected to the oil tank at a point below the oil level.

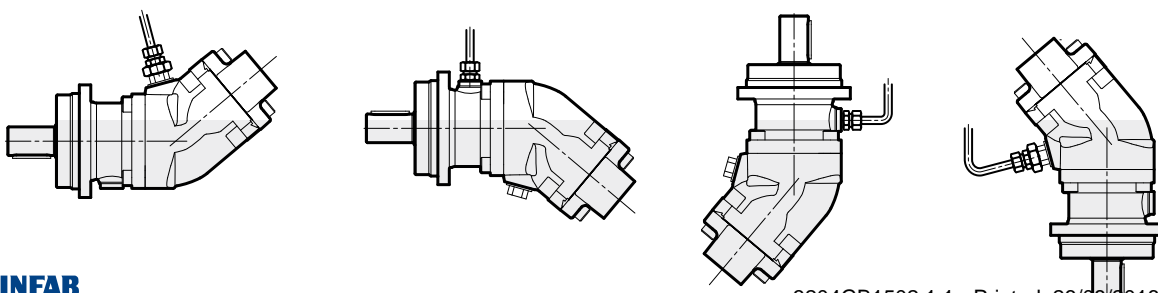

Piping

Recommended oil velocity in pressure line max. 7 m/sec

Filtering

Cleanliness according to ISO norm 4406, code 16/13.

Hydraulic fluids

High performance oils meeting ISO specifications – such as HM, DIN 51524-2 HLP, or better – must be used.

A min. viscosity of 10 cSt is required to keep the lubrication at a safe level.

The ideal viscosity is 20 - 40 cSt.

Additional technical data

Noise levels and bearing life calculations available on request. Please contact Sunfab!

Useful formulaes

Required flow rate $Q = \frac{D \times n}{1000 \times \eta_v}$ litres/min.

Speed $n = \frac{Q \times 1000 \times \eta_v}{D}$ RPM

Torque $M = \frac{D \times \Delta p \times \eta_{hm}}{6.3}$ Nm

Power $P = \frac{Q \times \Delta p \times \eta_t}{60}$ kW

D = displacement, cm³/revolution

n = speed, revolution/min

P = power, kW

Q = flow rate, litres/min

η_v = volumetric efficiency

η_{hm} = hydraulic-mechanical efficiency

η_t = overall efficiency = $\eta_v \times \eta_{hm}$

M = torque, Nm

Δp = pressure difference between the hydraulic motor inlet and outlet, MPa



WARNING

When the motor is in use:

1. Do not touch the pressure pipe
2. Beware of rotating parts
3. The motor and pipes can reach high temperatures

*Sunfab reserves the right to make changes in design and dimensions without notice. Printing and typesetting errors reserved.
© Copyright 2015 Sunfab Hydraulics AB. All Rights Reserved.*