



Sunfab's SCM 025-108 M2 is a range of robust axial piston motors with cartridge flange especially suitable for winch-, slewing-, wheel- and track drives.

SCM 025-108 M2 is of the bent-axis type with spherical pistons. The design results in a compact motor with few moving parts, high starting torque and high reliability. The SCM 025-108 M2 covers the entire displacement range 25-108 cm³/rev. at a maximum pressure of 400 bar.

It's well dimensioned, double tapered roller bearings permit high shaft loads and lead to excellent speed characteristics. It's high level of reliability is based on the choice of materials, hardening methods, surface structures and the quality assured manufacturing process.

Other advantages:

- High maximum speed
- Smooth operation over the entire speed range
- High efficiency
- Suitable for applications with high angular accelerations due to its high rotary stiffness

Motor SCM 025-108 M2		025	034	040	047	056	064	084	090	108
Displacement	cm ³ /rev	25.4	34.2	41.2	47.1	56.7	63.5	83.6	90.7	108.0
Working pressure										
<i>max intermittent</i>	bar	400	400	400	400	400	400	400	400	350
<i>max continuous</i>		350	350	350	350	350	350	350	350	300
Revolutions										
<i>max intermittent</i>	rpm	7000	7000	6300	6300	6300	6300	5200	5200	5200
<i>max continuous</i>		6300	6300	5700	5700	5700	5700	4700	4700	4700
<i>min continuous</i>		300	300	300	300	300	300	300	300	300
Power										
<i>max intermittent</i>	kW	86	115	125	145	175	195	215	230	230
<i>max continuous</i>		40	55	60	65	80	90	100	110	110
Starting torque theoretical value	Nm/bar	0.40	0.54	0.66	0.75	0.89	1.00	1.33	1.44	1.71
Moment of inertia (x 10 ⁻³)	kg m ²	1.1	1.1	2.6	2.6	2.6	2.6	7.4	7.4	7.4
Weight	kg	11.0	11.0	18.3	18.3	18.3	18.3	26.0	26.0	26.0

Data concerning RPM are based on maximum permitted peripheral velocity of the tapered roller bearing.
 Max intermittent power data may vary dependent on application. For further information please contact Sunfab.
 Continuous power data are based on maximum output power without external cooling of the motor housing.
 Intermittent duty is defined as follows: max 6 seconds per minute, e g peak RPM when unloading or accelerating.

Versions, main data

Example

SC	M	-	025	W	-	N	-	M21	-	W30	-	V2	M	-	1	00
Line	1		2	3		4		5		6		7	8		9	10

Line	SC	Sunfab Compact, bent-axis design
------	----	----------------------------------

1. Type	M	Motor
---------	---	-------

2. Displacement	025	034	040	047	056	064	084	090	108
-----------------	-----	-----	-----	-----	-----	-----	-----	-----	-----

3. Direction of rotation	W	Independent
--------------------------	---	-------------

4. Sealing	N	Nitrile
	H	High pressure, nitrile
	V	Viton

5. Mounting flange		025	034	040	047	056	064	084	090	108
M21	∅ 135	X	X	-	-	-	-	-	-	-
M22	∅ 160	-	-	X	X	X	X	-	-	-
M23	∅ 190	-	-	-	-	-	-	X	X	X

6. Shaft		025	034	040	047	056	064	084	090	108
Spline DIN 5480										
W30	W30x2x14x9g	X	X	X	X	X	X	-	-	-
W35	W35x2x16x9g	-	-	X	X	X	X	X	X	X
W40	W40x2x18x9g	-	-	-	-	-	-	X	X	X

X = Standard, preferred
(X) = Available, option
O = Contact Sunfab

7. Connection cover		025	034	040	047	056	064	084	090	108
V1	90° Mount flange vertical *	-	-	-	-	-	-	X	X	X
V2	90° Mount flange horizontal *	X	X	X	X	X	X	X	X	X

* According to SAE J518 code 62

8. Connections		025	034	040	047	056	064	084	090	108
M	Metric	X	X	X	X	X	X	X	X	X

9. Additional		External drainage
1		

10. Accessories		No accessories available
00		

SCM 025-034 M2

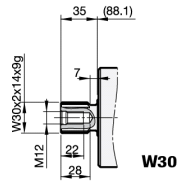
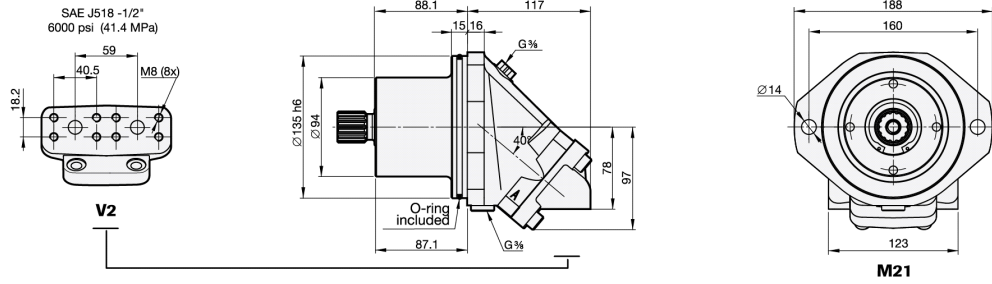

SCM 040-064 M2

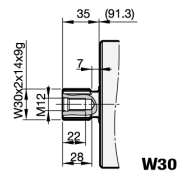
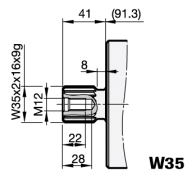
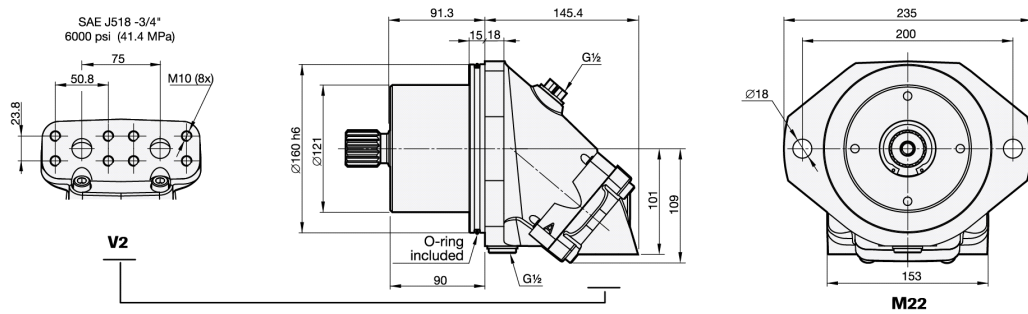

SCM 084-108 M2

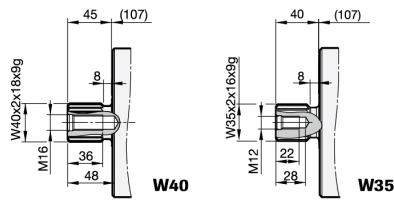
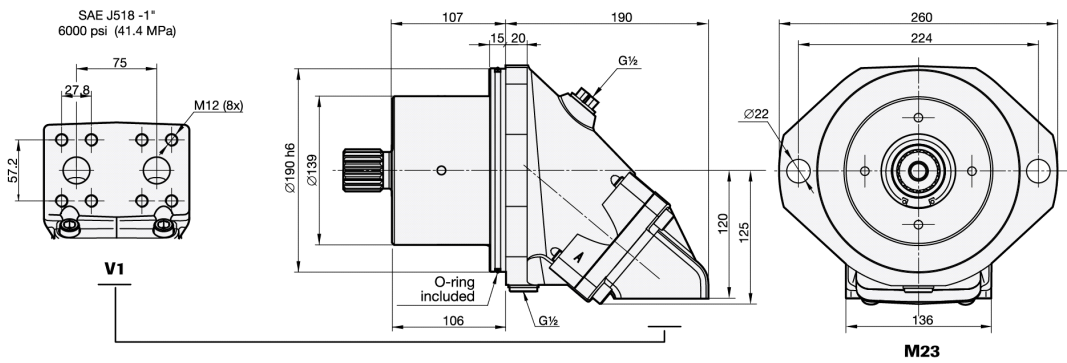
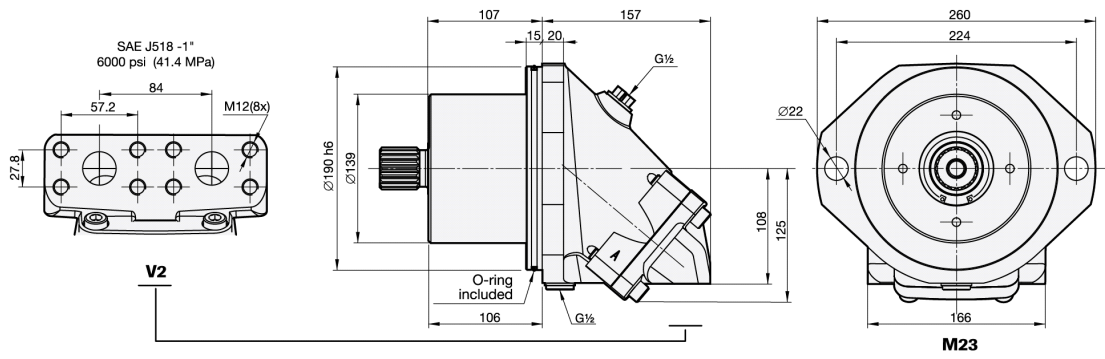

General instructions

Choice of shaft seal

Motor SCM	Code	Temp.	Max. housing pressure bar at rpm						
		°C	1000	2000	3000	4000	5000	6000	7000
025–064	N	75	5.5	2.7	1.8	1.4	1.1	0.9	0.8
	H	75	24,6	12,3	8.2	6.1	4.9	4.1	3.5
	V	90	5.5	2.7	1.8	1.4	1.1	0.9	0.8
084–108	N	75	3.8	1.9	1.3	1.0	0.8	0.6	
	H	75	17,2	8.6	5.7	4.3	3.4	2.9	
	V	90	3.8	1.9	1.3	1.0	0.8	0.6	

Code according to page 2, Versions, main data

Factors affecting the choice of shaft seal include the hydraulic motor housing pressure and the drainage oil temperature.

The drainage oil should have a maximum temperature of 75 °C with a Nitrile shaft seal and 90 °C with a Viton shaft seal. These temperatures must not be exceeded.

The housing pressure must be equal to or greater than the external pressure on the shaft seal.

Shaft loads

The life of the motor is highly dependent on the bearing life. The bearings are affected by operating conditions such as speed, pressure, oil viscosity and filtration.

External load on the shaft, as well as its size, direction and location also affects the bearing life.

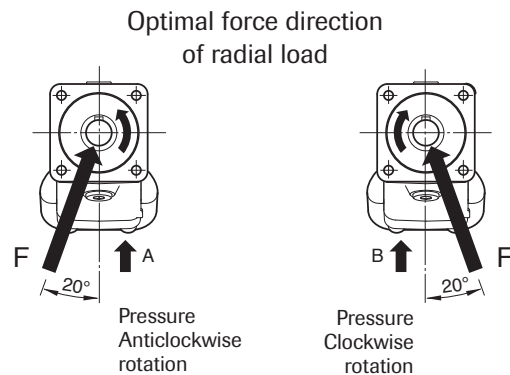
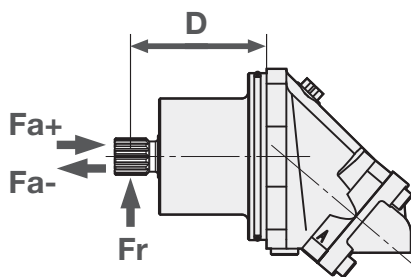

SCM M2 Max recommended shaft loads		025	034	040	047	056	064	084	090	108
Fr (radial) max ¹	kN	7.5	7.5	7.5	8	8.5	8.5	14.5	14.5	15
Distance D (to point of force)	mm	100	100	110	110	110	110	120	120	120
Fa (axial) + (at standstill/ 0 bar pressure) max	kN	3	3	4	4	4	4	5	5	5
Fa (axial) - (at standstill/ 0 bar pressure) max	kN	7	7	7	7	10	11	13	14	16
Fa (axial) + (at 400 bar pressure) max ²	kN	7	7	7	7	10	11	13	14	16
Fa (axial) - (at 400 bar pressure) max ²	kN	0	0	0	0	0	0	0	0	0

¹) Fr (radial) max; Calculation based on running conditions: 300 bar / 2000 rpm

¹) Fr (radial) max; Calculation based on optimal force direction (Fr max will be lower in other force directions)

¹) Fr (radial) max; In running conditions higher than 300 bar and/or 2000 rpm the max limits for Fr (radial) max will be lower

²) Fa (axial) + Will increase bearing life

²) Fa (axial) - Will decrease bearing life

For other forces, please contact Sunfab for advice.

Temperatures/Housing cooling

Excessive system temperature reduces the life of the shaft seal and can lower the oil viscosity below the recommended level. A system temperature of 60 °C and a drain flow temperature of 90 °C must not be exceeded.

Cooling/flushing of the motor housing can be needed to keep the drain flow temperature at an acceptable level.

Suggested flow:

Motor SCM	Flushing l/min	Cont. RPM
025-034	2-8	≥ 2800
040-064	4-10	≥ 2500
084-108	6-12	≥ 2200

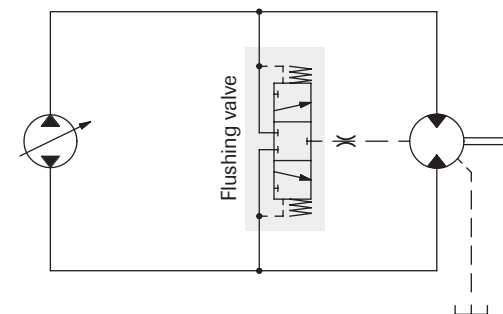
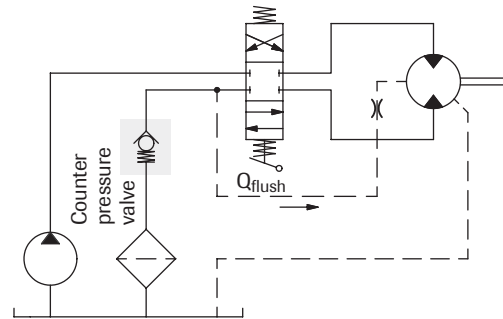
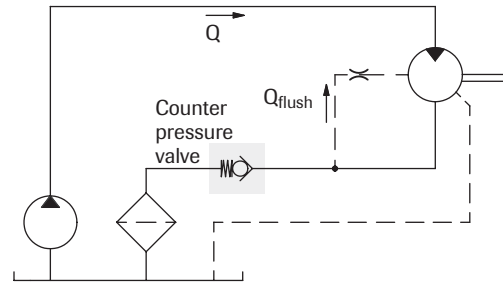
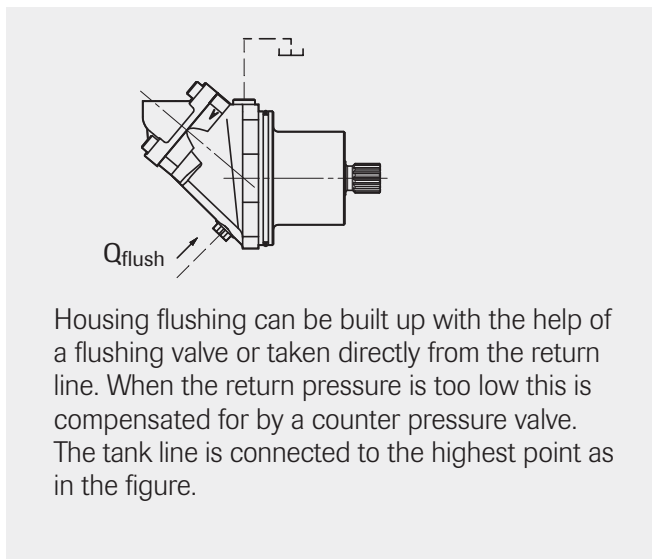

Simplified circuits

Installation

- The motor housing should be filled with oil to at least 50% before starting.
- The drainage pipe should be connected to topmost drainage outlet.
- The other end of the pipe should be connected to the oil tank at a point below the oil level.

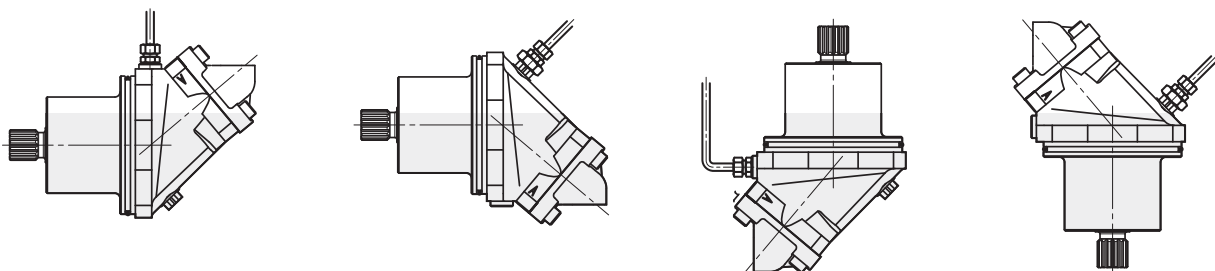

Piping

Recommended oil velocity in pressure line max. 7 m/sec

Filtering

Cleanliness according to ISO norm 4406, code 16/13.

Hydraulic fluids

High performance oils meeting ISO specifications – such as HM, DIN 51524-2 HLP, or better – must be used.

A min. viscosity of 10 cSt is required to keep the lubrication at a safe level.

The ideal viscosity is 20 - 40 cSt.

Additional technical data

Noise levels and bearing life calculations available on request. Please contact Sunfab!

Useful formulaes

Required flow rate $Q = \frac{D \times n}{1000 \times \eta_v}$ litres/min.

Speed $n = \frac{Q \times 1000 \times \eta_v}{D}$ RPM

Torque $M = \frac{D \times \Delta p \times \eta_{hm}}{6.3}$ Nm

Power $P = \frac{Q \times \Delta p \times \eta_t}{60}$ kW

D = displacement, cm³/revolution

n = speed, revolution/min

P = power, kW

Q = flow rate, litres/min

η_v = volumetric efficiency

η_{hm} = hydraulic-mechanical efficiency

η_t = overall efficiency = $\eta_v \times \eta_{hm}$

M = torque, Nm

Δp = pressure difference between the hydraulic motor inlet and outlet, MPa



WARNING

When the motor is in use:

1. Do not touch the pressure pipe
2. Beware of rotating parts
3. The motor and pipes can reach high temperatures

*Sunfab reserves the right to make changes in design and dimensions without notice. Printing and typesetting errors reserved.
© Copyright 2015 Sunfab Hydraulics AB. All Rights Reserved.*