



# DHOLLANDIA



## POCKET GUIDE PRODUCT RANGE 2015



**DHOLLANDIA**

**POCKET GUIDE  
PRODUCT RANGE 2015**



# Content list

DHOLLANDIA facts & figures	Pg 3
6 good reasons to buy DHOLLANDIA	Pg 4
Best possible protection for your investment	Pg 6
Different types of RIDE	Pg 8
Control units for all applications...	Pg 10
... and an endless list of options to choose from	Pg 12
Professional service network Original spare parts	Pg 13
Reading help	Pg 14
Chapter 1 • Passenger lifts	Pg 16
Chapter 2 • Lifts for factory built panel vans	Pg 42
Chapter 3 • Cantilever lifts	Pg 66
Chapter 4 • Slider lifts	Pg 100
Chapter 5 • Fold-away lifts	Pg 126
Chapter 6 • Special hydraulic applications	Pg 144
Chapter 7 • Column lifts	Pg 162

# DHOLLANDIA facts & figures

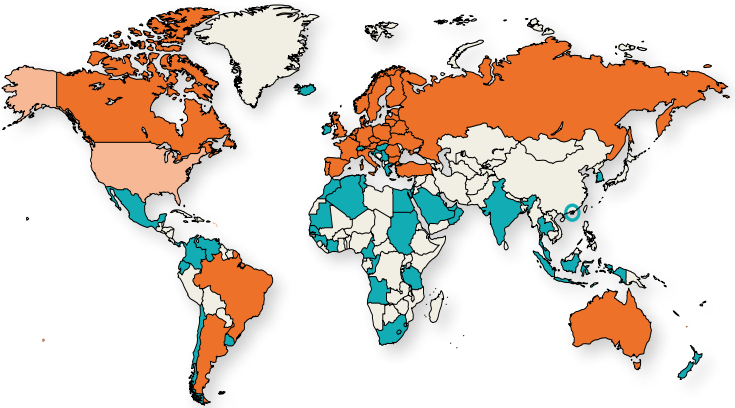
- Founded in 1968, more than 45 years of experience in the tail lift business
- Europe's N° 1 manufacturer of tail lifts, with production in excess of 35,000 units per year and more than 550,000 units sold since 1968
- Unparalleled product range with lift capacities ranging from 150 to 16,000 kg, all developed via internal growth
- Production sites in 5 countries
- Extensive vertical integration and technological leadership: more than 90% of mechanical, hydraulic and electrical parts used are manufactured in-house
- Professional network of DHOLLANDIA Area Sales & Service Centres (Europe) and independent distributors (outside Europe) in 6 continents and more than 60 countries worldwide



 DHOLLANDIA Group       Independent distributor



See [www.dhollandia.com](http://www.dhollandia.com) for our worldwide network.



# 6 good reasons to buy DHOLLANDIA



## 1- Safe & reliable



- No electronic components, exceptionally reliable
- Adapted to the intensive use and heavy duty work
- Strong & robust 4-cylinder tail lifts (\*)
- Electrical safety valves mounted to all cylinders (\*)
- Manual emergency back-up operation on all electro valves
- Level ride plus automatic tilt at ground level on most commercial lift models (\*)



## 2- Flexible & client-oriented

- Small enough to care, big enough to cope
- Wide range of standard products ranging from 150 to 16,000 kg
- Extensive vertical integration and technological leadership: more than 90% of all mechanical, hydraulic and electrical parts used are manufactured in-house
- Therefore perfectly geared up to develop and manufacture tailor-made lifts and creative client-oriented solutions



## 3- Superior finish

- Low maintenance bearings and grease nipples in all critical articulation points
- Piston rods in hard-chromed stainless steel for all cylinders exposed to adverse weather conditions
- Best possible protection against corrosion: **HOT-DIP ZINC PLATED finish** or **Protection PLUS finish** on the majority of lifts





#### **4- Economic & budget friendly**

- Optimum price-quality ratio
- Lifts designed to allow easy maintenance
- Attractive spare parts prices and low maintenance costs
- Longer life-time and durability



#### **5- Strong environmental focus**



- Use of Best Available Techniques in surface treatment and waste water treatment
- Use of rain water for industrial purposes
- Application of wind and solar energy to power manufacturing processes
- Maximum elimination of lost packaging material
- ISO 14001 certified



#### **6- The safe and clever buy**

- Modern lift range offering many safety features and functional options
- Professional service network in more than 60 countries across the world
- More than 550.000 units sold are the proof of customer satisfaction and loyalty
- Preferred choice of many transport companies, fleet-owners, rental companies and truck body manufacturers

(\*) Generic characteristics for most types of commercial lifts

# Best possible protection for your investment

DHOLLANDIA uses 2 premium surface treatment finishes for steel components, raising the quality and corrosion protection of the finished product to the absolute top in the tail lift industry.

Most popular commercial lifts are supplied in **HOT-DIP ZINC PLATED finish**, the less common lifts in **Protection PLUS finish**.



DHOLLANDIA's **Protection PLUS** paint finish combines innovative technologies to raise the quality and corrosion protection of its tail lifts to the highest level.

Protection PLUS incorporates 4 important steps:

1. Shot blasting of the steel substrate
2. 3-cation zinc phosphate
3. KTL cathodic dip epoxy coating (KTL = Katodische Tauch-Lackierung)
4. Polyester powder top coat

## E-coat (KTL)



## Polyester powder coat



**HOT-DIP ZINC PLATING** is based on the metallurgic bond between the steel parts and zinc, melted at 460 °C. The zinc-iron alloys formed in this way, offer a number of clear advantages:

**HOT-DIP  
ZINC PLATED**

- ▶ **Best possible protection against corrosion**
- ▶ Improved metallurgic characteristics
- ▶ Better protection against shocks and wear
- ▶ Protects the outside **and inside** of steel structures (unlike e-coat or conventional paint systems, whose effect is limited to the painted outside surfaces)

**Hot zinc melted at 460 °C**



Green technology: life cycle assessments have proven that zinc-plating is the most environmentally friendly method of anti-corrosion protection.



# Different types of RIDE

The **RIDE** of a lift describes the movement that its platform goes through when lowering from the vehicle floor to the ground; or vice versa when lifting from the ground to the vehicle floor.

DHOLLANDIA mainly uses 3 types of rides.

## 1 Wedge or conical platform Level ride + automatic tilt at ground level

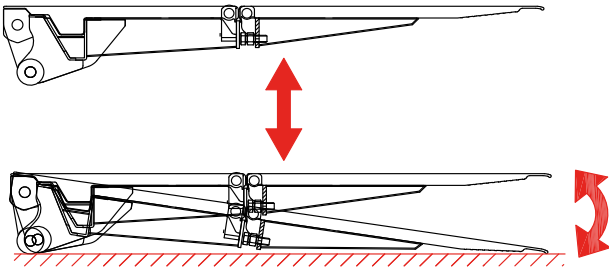

When lowering, the platform remains level from the vehicle floor down until the platform rollers touch the ground. Next, the platform tilts down to an inclined position that allows loading and unloading.

When lifting off the ground, the platform first tilts up from its inclined position on the ground to the horizontal level, then continues a level ride to the vehicle floor.

### Recommended for:

- ▶ higher capacity applications, heavier loads
- ▶ applications where easy on- and off-loading of pallets with pallet jacks is required
- ▶ applications where adjustable platform orientation is required (tilt cylinders)

### Used on:

DH-L and DH-S lifts, most DH-R lifts

## ② **Half-dip ride**

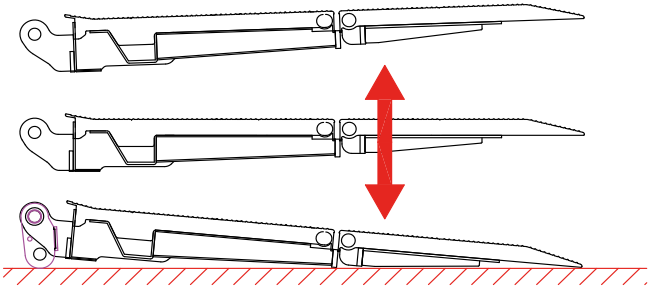

When lowering, the platform progressively tilts down from a level position at the vehicle floor to an inclined position at the ground. (And vice versa when lifting).

### Recommended for:

- ▶ applications where the load is stable on the platform: parcels, tyres, boxes, white & brown goods, drums, etc...
- ▶ Low-budget, low-maintenance environment

### Used on:

DH-RP lifts

## ③ **Flat platform level ride**

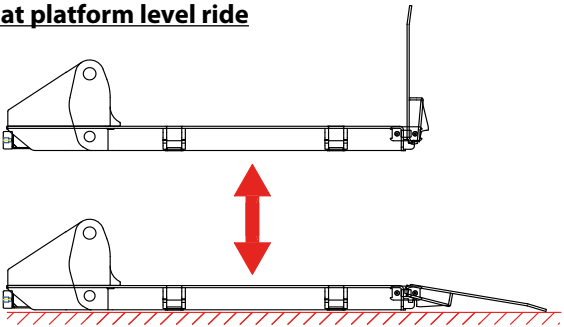

The platform remains level during the full lifting / lowering cycles. The rear end of the platform can be a fixed leading edge, or hinged ramps which adjust more easily to uneven surfaces.

### Recommended for:

applications where the load is unstable on the platform: roll-cages, tall and top-heavy objects

### Used on:

DH-LK and DH-SK lifts, most column lifts, most passenger lifts

# Control units for all applications...



DHOLLANDIA offers a wide variety of different control units to suit particular lift models, special applications and the client's individual requirements. Instructions for mounting and risk analysis are available in the mounting instructions.

## Most popular auxiliary controls



OAE001



OAE005



OAE011



OAE015



OAE060



E0452 / E0453

## Most commonly used exterior control boxes

(conform with CE safety regulations, all exterior control boxes sold in Europe have mandatory 2-hand control)



### **OAE030.BT**

Exterior control box with joy-stick, safety switch and main battery isolator switch



### **OAE031.Z (OAE035.Z)**

3+1 button (or 4+1 button) control unit, integrated in the body panel, or mounted under the vehicle body, without isolator switch



### **OAE039.BP**

Exterior control unit incorporated in the cover of the pump unit, with joy-stick, safety switch and main battery isolator switch



### **OAE041.BP**

Arctic exterior control box with IP67 rated push buttons, safety switch and main battery isolator switch



### **OAE043.BT**

Slim-line arctic exterior control box with IP67 rated toggle switches and main battery isolator switch



## ... and an endless list of options to choose from



**DHOLLANDIA** offers an almost endless list of electrical, hydraulic and mechanical options to fine-tune the lift to the client's individual requirements.

The most popular options involve:

- ▶ Control & ergonomics: various main and auxiliary controls
- ▶ Visibility: flashing platform lights & flags
- ▶ Load handling: roll-stops for pallets and roll cages
- ▶ Stability: hydraulic and mechanical stabilising legs
- ▶ Access: side loading ramps
- ▶ Operator safety: safety rails and fall protection, anti-slip platform surface finish & coatings
- ▶ Installation: quick-fit mounting solutions, plug & play connections
- ▶ Independence: battery & charging systems
- ▶ Finish: HOT-DIP ZINC PLATING, Protection Plus or individualised RAL colour schemes

# Professional service network

## Original spare parts



**DHOLLANDIA spare parts =**  
**100% original**  
**100% reliable**  
**100% compatible**

DHOLLANDIA lifts are being distributed in more than 60 countries worldwide, through a dedicated and professional network of DHOLLANDIA Area Sales & Service Centres and official independent distributors.

Each of these country distributors holds substantial stock of lifts and original spare parts and can support clients with:

- ▶ commercial and technical advice
- ▶ maintenance, repair and road-side assistance
- ▶ fitting and fitting assistance
- ▶ training on any of the subjects above and operator training

# Reading help

## Lift capacity

Hydraulic tail lifts are not designed to LIFT / LOWER weights corresponding to their nominal capacity over the full surface of the platform. The nominal capacity is valid at a certain distance or centre of gravity, measured behind the rear of the vehicle body. Behind that centre, which is marked on the platform, the maximum safe working load of any brand of tail lifts diminishes according to specific load diagrams supplied with the lift.

Since lifts are being sold in many capacities and with various centres of gravity, it may seem a difficult task to make an objective comparison. Therefore, the concept load moment combines the nominal lift capacity with the applicable centre of gravity. It allows us to compare the total performance of the machine and to get some appreciation of its ability to endure heavy duty conditions over a longer time period.

Load moment = lift capacity x centre of gravity

Example: 2 lifts with identical capacity but different centre of gravity:

### Type DH-LM.20 :

CAP	CG	LM
1500 kg	750 mm	11.25 kNm
2000 kg	750 mm	<b>15 kNm</b>

### Type DH-LM.30 :

CAP	CG	LM
1500 kg	1000 mm	15 kNm
2000 kg	1000 mm	<b>20 kNm</b>
2500 kg	1000 mm	25 kNm
3000 kg	1000 mm	30 kNm



$$2000 \text{ kg} \times 750 \text{ mm}$$
$$20 \text{ kN} \times 0.75\text{m} = 15 \text{ kNm}$$

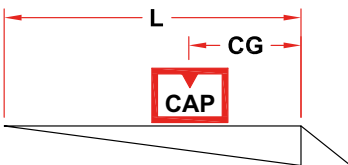

$$\text{LM} = \text{CAP} \times \text{CG}$$

CAP = nominal lift capacity  
CG = centre of gravity  
LM = load moment = CAP x CG

## Units of measurement

Unless stated otherwise within the text, all weights are expressed in kg and all dimensions in mm.

## Weight indications of the lifts

### Weights:

STEEL platform	
1750 mm	? kg
2000 mm	? kg

ALU platform	
1800 mm	? kg
2000 mm	? kg

DHOLLANDIA lifts are available with a wide choice of different lift arms, lift frames and mounting plates, to allow integration to a wide variety of vehicles in optimum circumstances. Furthermore, most lifts are available with different platform designs and a long list of options to adapt the lift to the client's individual needs.

As a consequence, the weights mentioned in our sales literature are indicative and must be read : "from ... kg onwards". The real weights might vary according to the type of vehicle and the execution of the lift. Ask your national DHOLLANDIA distributor for further detail.

## Voltage

Unless stated otherwise within the text, all systems mentioned are designed for 12V - 24V commercial vehicles. Other voltage systems are available on request.

## Half width platforms, foldable platforms

All types of cantilever lifts (see chapter 3) are available with the standard platform, covering the full width of the vehicle body. But certain types are also available with half width or partial width platforms and vertically foldable platforms.

This possibility is indicated as follows:



Full width platform available



Half / partial width platform available



Half width frame + foldable platform available



Half / partial width platform not available



Half width frame + foldable platform not available





# 6

## Special applications





→ Manual ramp for vans, trucks, trailers and semi-trailers

## DH-AM.25 • 1000-2500 kg



The DH-AM is a **light weight yet robust manual ramp**, equipped with a full aluminium platform. The opening and closing of the platform is reinforced by powerful torsion springs, invisibly incorporated in the platform articulation points. The platform is mechanically locked on the left and right sides.

The DH-AM can be mounted at the rear or at the side doors of a wide variety of commercial vehicles. On factory built panel vans, the DH-AM can be supplied as a body kit replacing the rear vehicle doors (option OAT200).

This manual ramp can be used for a wide array of different applications, and forms a light-weight and simplified alternative for hydraulically driven ramps or genuine tail lifts.

### Load capacity

CAP
1000 kg
2500 kg

### Weights [see pg. 15]

ALU	
2000 mm	120 kg

# Easy-to-use manual ramp with aluminium platform



## Technical specifications

Lift frame	2 heavy duty hinges mounted on the left and right side of the door aperture
Cylinders	None. Manual opening & closing of the platform reinforced by powerful torsion springs.
Platform material	Aluminium, natural mill finish
Standard platform depths	2000 mm Other depths available on request (OAP302.A)
Standard platform widths	Variable per increments of 5 mm



→ Hydraulic ramp for vans, trucks, trailers and semi-trailers

## DH-AC.10 • 1000 kg



The DH-AC is a **light weight hydraulic ramp** with aluminium platform and superior aesthetic finish. As the closing mechanism is incorporated in 2 columns mounted in the door aperture of the vehicle body, no parts of the closing mechanism (springs, cylinders,...) are visible from the outside.

The DH-AC is traditionally used for the transport of horses or other animals. More recently, it is also being used for other applications, such as the collection of waste bins, the transport of garden equipment (small tractors, lawn mowers, ...).

For the transport of live animals, columns made of stainless steel are available (option OAT130).

# Light hydraulic ramp with aluminium platform

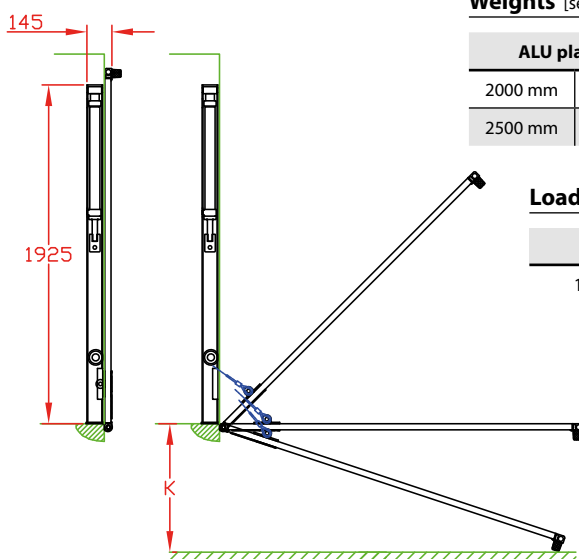

## Weights [see pg. 15]

ALU platform	
2000 mm	210 kg
2500 mm	235 kg

## Load capacity

CAP
1000 kg

## Technical specifications

Lift frame	2 vertical columns of 90x90 mm, mounted in the door aperture, against the frame of the body
Cylinders	2 cylinders (1 in each column)
Platform material	<ul style="list-style-type: none"> <li>Aluminium, natural mill finish</li> <li>3 hinge blocks, to be welded or bolted to the rear cross member of the vehicle floor</li> </ul>
Standard platform depths	2000 - 2500 mm Other depths available on request (OAP302.A)
Standard platform widths	Variable per increments of 5 mm
Standard control unit [see pg. 11]	OAE030.BT
Standard finish of the lift frame	Protection PLUS [OAT102]



→ Hydraulic ramp for trucks, trailers and semi-trailers

## DH-AR... • 3000 - 16000 kg



The **DH-AR1...** are basic ramps with a **non-articulated steel platform**.

The **DH-AR2...** are ramps with a **longer, articulated platform**. The top and bottom platform sections are linked with **stabilisers**, so that they work synchronised, as a pair.

The **DH-AR3/4...** also have a **longer, articulated platform**. But the top and bottom platform sections are linked with **2 additional hydraulic cylinders**, so that both platform sections can be operated independently. The DH-AR4... can be used as bridge at the loading dock.

### Load capacity

CAP
3000 kg
5000 kg
9000 kg
16000 kg

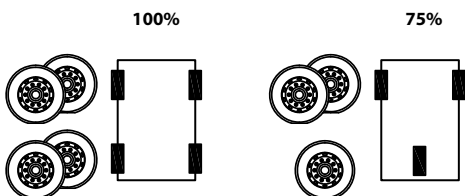

# Heavy duty hydraulic ramp with steel platform

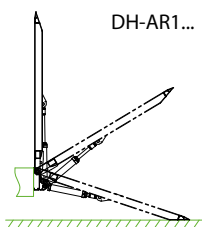

DH-AR1...

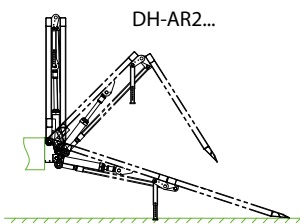

DH-AR2...

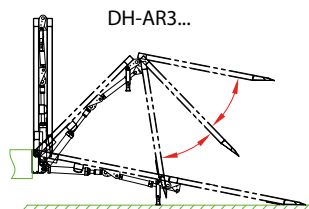

DH-AR3...

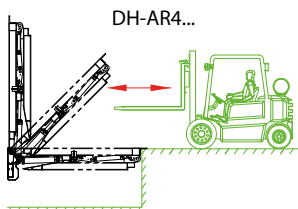

DH-AR4...

## Technical specifications

Lift frame	140 x 80 mm tube mounted at the rear cross member of the loading floor
Cylinders AR1...	2 tilt cylinders
Cylinders AR2...	2 tilt cylinders + 2 stabilisers
Cylinders AR3 / 4...	2+2 tilt cylinders
Hydraulic stabilising legs	Available as an option (OAH010)
Standard platform depths	AR1...: 2500 mm AR2-3-4: 2000 + 2000 mm Other depths on request (OAP302.S)
Standard platform width	Variable per increments of 5 mm
Standard control unit	Exterior control box with turn buttons, a safety switch and battery isolator switch
Standard finish of the lift frame	Protection PLUS [OAT102]





→ Hydraulic ramp for loading docks

## DH-DR.90 • 9000 kg



The ramp DH-DR.90 is equipped with a very robust steel platform, offering **9T bridge capacity between a fixed loading station and a commercial vehicle.**

The ramp is hydraulically operated by a single lift cylinder, driven by a 380V pump unit.

The hydraulic system and the shape of the platform point allow the operator to correctly line-up the platform with trucks, trailers and semi-trailers with different loading floor heights; and to follow the movement of the vehicle floor while loading and unloading (variations in vehicle suspension).

The platform sides are foreseen with sturdy guards, to prevent fork lifts from unintentionally driving off the platform sides.

# Heavy duty hydraulic ramp for loading docks

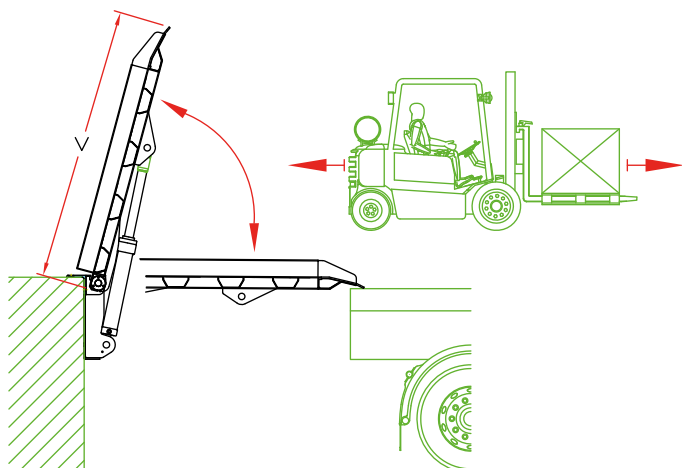

## Load capacity

<b>CAP</b>
9000 kg



## Technical specifications

Lift frame	Solid mounting plate to be installed on the loading dock, incorporating the articulation points and the lift cylinder anchor point
Cylinders	1 central lift cylinder
Platform material	Reinforced steel platform
Standard platform depths	1700 mm Other depths on request (OAP302.S)
Standard platform width	2000 mm Other widths on request (OAP303)
Standard control unit	2-button control integrated in the 380V pump unit
Standard finish of the lift frame	Protection PLUS [OAT102]



→ Cantilever lift for trucks, trailers and semi-trailers

## DH-LKG.05 • 500 kg



The **DH-LKG.05** is a robust cantilever lift, designed for the **distribution of gas bottles**. It is equipped with a flat platform to give maximum stability to the gas bottles while lifting / lowering and is available with various types of safety rails, that allow to secure the bottles in vertical position.

In order to keep the operation as simple as possible, the platform is opened / closed by hand, supported by powerful torsion springs. The reinforced steel platform offers 925x1100 mm useful loading space and allows to handle multiple bottles during any lift / lowering cycle, up to max. 500 kg safe working load.

### Lift capacity

CAP	CG	LM
500 kg	500 mm	2.5 kNm

### Weights [see pg. 15]

STEEL platform	
925x1100 mm	220 kg

# Flat platform, specially designed for gas bottles

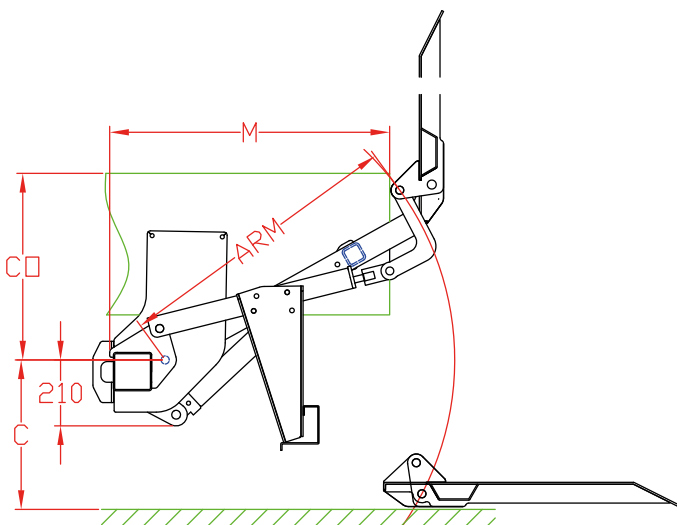

## Fitting dimensions

ARM		1000
K max.		1490
C max.		730
C min.		400
CO max.		760
M	at C max.	760
M	at C min.	975

OAP206.L / .R



OAP207



## Technical specifications

Lift frame	120 x 120 mm
Cylinders	1 central lift cylinder + 2 fixed stabilisers
Type of ride [see pg. 8-9]	Flat platform, level ride
Platform material	Steel
Standard platform dimensions	925 x 1100 mm (L x W) Other dimensions on request
Lift arm lengths	1000 mm
Lift arm width	350 mm
Standard control unit [see pg. 10]	OAE015 Fixed 2-button exterior control box
Standard finish of the lift frame	Hot-dip zinc plated finish [OAT104]



→ Lift for refrigerated bodies on trucks, trailers and semi-trailers

## DH-IV.10 • 1000 kg



The DH-IV is designed to **load / unload hanging meat**. To unload, the meat pending from the roof-rails is pulled onto the hooks mounted on the cross-tube between the lift arms of the lift and subsequently lowered to the ground by means of hydraulic cylinders.

The DH-IV is manufactured from **stainless steel**, conform with the regulations on health and hygiene.

The cross tube between the lift arms can be welded in a fixed position between the arms. Or it can rotate in a parallelogram configuration (option S406), so that the angle of the cross tube to the ground remains unchanged during the lift / lower movements.

### Lift capacity

CAP
1000 kg

### Weights [see pg. 15]

Stainless steel	
Standard	190 kg

# Specialised in hanging meat

Standard

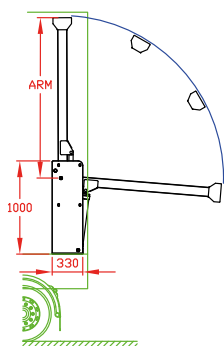

Option S406

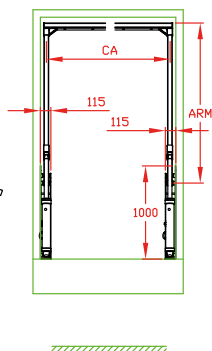
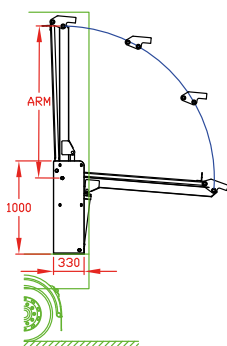

## Technical specifications

Lift frame	2 separate compact lift frames, to be mounted left and right of the door aperture, on the floor and against the side panel
Cylinders	2 double acting lift cylinders
Standard lift system	Fixed cross beam between the lift arms (to be welded during fitting). The angle between the cross beam and the ground changes as the lift goes up / down.
Lift system + option S406	Articulated cross beam (parallelogram) between the lift arms. The angle between the cross beam and the ground remains unchanged as the lift goes up / down.
Material	Stainless steel
Dimensions of lift arms	Length x width made to measure
Standard control unit	3-button control unit integrated in the frame of the lift



→ Bridge plate between truck and trailer

## DH-AP • 2x1250 kg



The aluminium ramps DH-AP are used for truck-trailer combinations, whereby the trailer is equipped with doors at the front side.

This **loading bridge** enables the operator to shift load from the truck to the trailer and vice versa, and to handle all the loading and unloading at the rear of the trailer, either by means of a tail lift, or at the loading dock.

The DH-AP consists of 2 hinged ramps of 1250x1200 mm, which are manipulated by hand from a vertical travel position just inside the rear doors of the truck body, to a horizontal work position between the 2 vehicles.

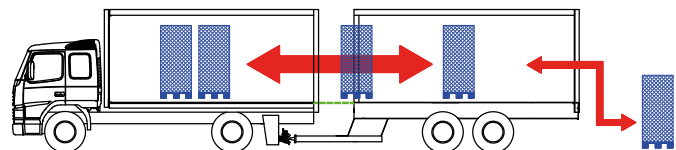

### Load capacity

CAP

2x1250 kg

### Weights [see pg. 15]

Alu platform

2x  
1250x1200 mm | 2x 36 kg

# Loading bridge between truck and trailer

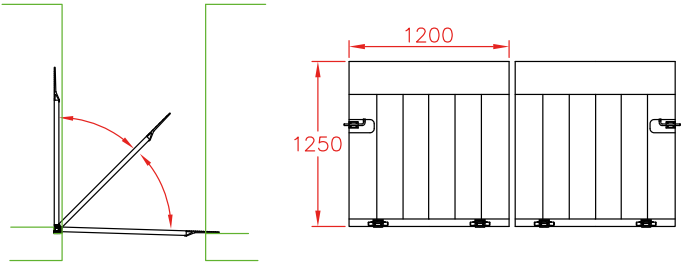

## Technical specifications

Mounting interface	2x2 steel hinge blocks to be bolted or welded to the vehicle floor of the vehicle
Cylinders	<ul style="list-style-type: none"><li>• None. The bridge plates are opened / closed manually.</li><li>• 2 mechanical locks to lock the platform in the closed travel position.</li></ul>
Platform material	Aluminium, natural mill finish
Standard platform dimensions	1250 x 1200 mm (L x W) Other dimensions on request

## DH-LM used as loading bridge



It is also possible to use a **truck-mounted DH-LM** as loading bridge between the 2 vehicles of the tandem. Such solution **increases the independence and flexibility of the truck**: equipped with its own load device, the truck can go solo in the town centers to distribute and deliver to shops.





→ Scissor lift for step deck trailers

## DH-H • 8000 kg



The **scissor lift** DH-H has a lift capacity of 8.000 kg and is specially designed to **load / unload the upper deck of step-deck trailers**.

The scissor itself is made at 800 mm width, but is equipped by a full-width loading table by the body builder, according to the required dimensions and surface finish.

Often, the loading floor and scissor lift deck of such semi-trailers are equipped with pneumatically lifted roller beds, for the manipulation of air-freight containers.

### Lift capacity

CAP
8000 kg

### Weights [see pg. 15]

Alu platform	
Scissor	850 kg

# The solution for step-deck trailers

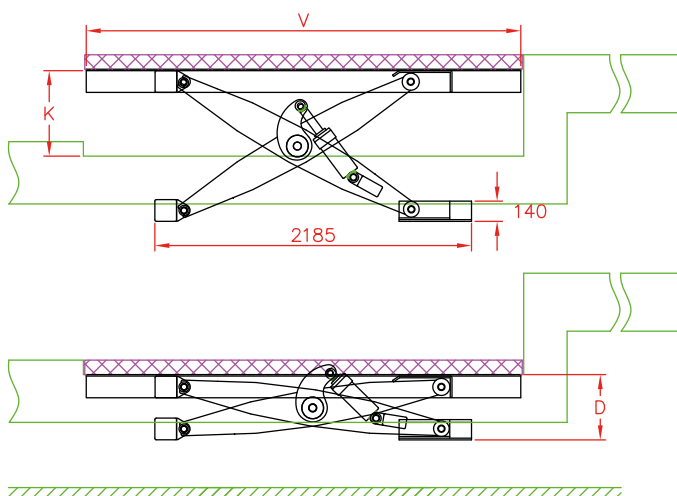

## Fitting dimensions

K max.	600 mm
D min.	450 mm

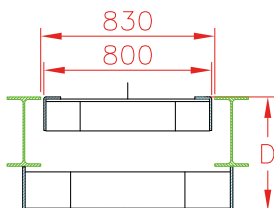

## Technical specifications

Lift frame	<ul style="list-style-type: none"> <li>• 1 fixed mounting tube + 1 roller bed to be mounted on the underside of the chassis I beams.</li> <li>• Top loading table to be manufactured by the chassis manufacturer.</li> </ul>
Cylinders	2 heavy duty lift cylinders
Scissor material	Steel
Scissor lift dimensions	800 x 3200 mm (W x L)
Maximum lift height	600 mm
Standard control unit [see pg. 10]	OAE001
Standard finish of the lift frame	2K primer

[www.dhollandia.com](http://www.dhollandia.com)



## **DHOLLANDIA**

IZ E17-1072 Zoomstraat 9 • 9160 Lokeren • Belgium  
Tel. +32 (0)9 349 06 92 • Fax +32 (0)9 349 09 77  
[www.dhollandia.com](http://www.dhollandia.com) • [info@dhollandia.be](mailto:info@dhollandia.be)

---

### **DHOLLANDIA UK LTD**

7 Latham Road • Huntingdon, Cambridgeshire  
PE29 6YG • United Kingdom  
Tel. +44 1480 435 266 • Fax +44 1480 431 823  
[info@dhollandia.com](mailto:info@dhollandia.com)